



- Easily configurable for radial or tangential mounting
- High stability three point mounting
- Fully welded and sealed to IP68 / IP69K
- Load cell removal without jacking or dummies
- Substantial lift off prevention
- Stainless steel OIML C3 approved load cell
- M12 connectors

Thames Side LeverMount Patented Weighing Assembly

LeverMount's® unique patented design is such that no separate support arrangements are necessary to raise and lower the vessel. The base casting itself provides a stable load-bearing platform prior to installation of the load cell. Once the vessel is in position and the two transit bolts are removed, the load cell is used as a lever to raise the top plate of the mount into the working position, regardless of whether the vessel is empty or full.

Top plate movement in the lateral and rotational axis making it tolerant of steel work misalignment avoiding any mechanically induced errors.

The stainless steel, IP68/IP69K, fully welded, load cell makes it suitable for use in harsh environments.

The LeverMount® allows for substantial labour saving to be made and improved safety due to simple installation and removal of load cells.

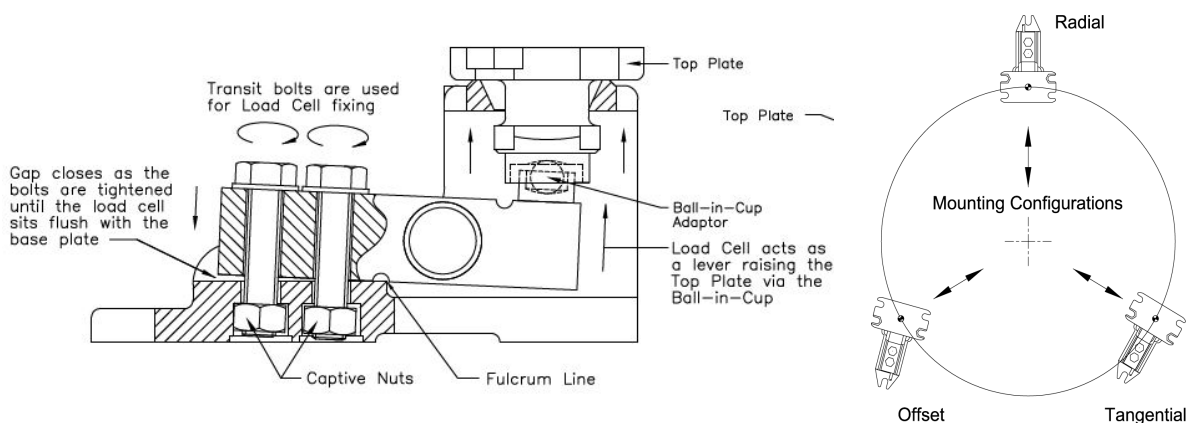



Specification Table

LeverMount	
Load Cell Capacities	2t
Operational Temperature Range	-20 to +70°C
Environmental Protection	IP68/IP69K
Cable Length	5 m
Material	Stainless Steel

Specifications are subject to variation for improvement, without notice Illustrations are indications only

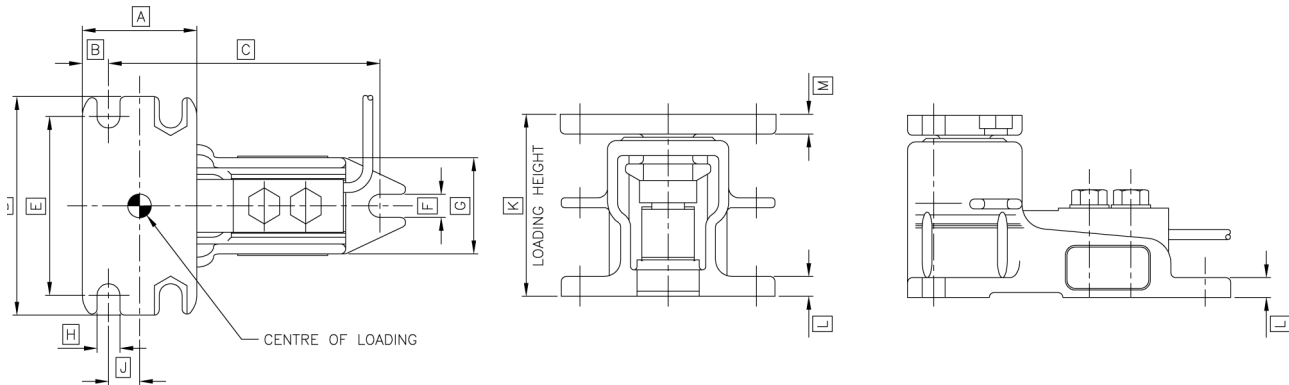

Capacity (kg)	A	B	C	D	E	F	G	H	J	K	L	M
20, 50, 100, 200	70	16	147	100	80	9	55	9	19	80	7	8
300, 500, 1000, 2000	70	16	168	132	108	14	60	14	19	110	12	12
3000, 5000	100	25	225	190	150	22	80	22	25	164	15	20

All dimensions in mm.

<p>MC5J4 - 4 way load cell junction</p> 	<p>Junction Box to Indicator Load cell Cables:</p> <p>MC501 Cable, 5Pin M-F 5 Core 1m MC503 Cable, 5Pin M-F 5 Core 3m MC506 Cable, 5Pin M-F 5 Core 6m MC509 Cable, 5Pin M-F 5 Core 9m MC515 Cable, 5Pin M-F 5 Core 15m MC530 Cable, 5Pin M-F 5 Core 30m</p>
<p>Part Number: agWEIGHr-LM-2t Kit 4 Stainless Steel Load Cell, 2t and assembly</p>	<p>Distributed By:</p>